

TADANO CARGO CRANE

MODEL : **TM-ZE505GMH**

CRANE SPECIFICATIONS

<u>CRANE CAPACITY</u>	4,040 kg at 2.8 m (5-part line)
<u>BOOM</u>	Five-sectioned, fully powered partly synchronized telescoping boom of heptagonal box construction Retracted length ----- 3.77 m Extended length -----13.34 m Extending speed ----- 9.57 m / 25 s Elevation ----- Elevated by a double-acting hydraulic cylinder Elevating speed ----- 1° to 78° / 12 s Boom point ----- 3 sheaves
<u>WINCH</u>	Hydraulic motor driven Spur gear speed reduction, provided with mechanical brake and cable follower Single line pull ----- 7.92 kN {808 kgf} Single line speed ----- 76 m/min (at 4th layer) Wire rope Diameter x length --- 8 mm x 97 m Breaking strength --- 43.1 kN {4.39 tf} Construction ----- 7 x 7 + 6 x WS(26) Hook block ----- 2 sheaves
<u>HOOK STOWING DEVICE</u>	Mechanically stowed beneath boom top portion

RATED LIFTING CAPACITIES IN KILOGRAMS

Crane Strength Rated Capacities

Load Radius	3.77 m / 6.21 m Boom		Load Radius	8.59 m Boom		Load Radius	10.97 m Boom	Load Radius	13.34 m Boom
	Extension width of outriggers			Extension width of outriggers			Extension width of outriggers		Extension width of outriggers
	Full	Minimum		Full	Minimum		Full		Full
2.5 m and below	4,040	3,380	2.5 m and below	3,130	3,130	4.0 m and below	2,230	5.0 m and below	1,430
2.8 m	4,040	2,580	3.0 m	3,130	2,580	4.5 m	2,180	6.0 m	1,330
3.6 m	3,130	1,880	3.6 m	3,130	1,880	5.0 m	2,030	7.0 m	1,230
3.9 m	2,930	1,630	3.9 m	2,930	1,630	6.0 m	1,730	8.0 m	1,080
4.5 m	2,530	1,330	4.5 m	2,530	1,330	7.0 m	1,430	9.0 m	980
5.0 m	2,230	1,080	5.0 m	2,230	1,080	8.0 m	1,230	10.0 m	880
5.5 m	1,980	930	5.5 m	1,980	930	9.0 m	1,080	11.0 m	800
5.99 m	1,780	780	6.0 m	1,780	780	10.0 m	980	12.0 m	730
			6.5 m	1,630	700	10.75 m	900	13.12 m	650
			7.0 m	1,480	630				
			7.5 m	1,380	550				
			8.37 m	1,180	430				

NOTES : 1. The mass of hook block (45kg), slings and all similarly used load handling devices must be added to the mass of the load.

2. The above numerical values of total rated loads are based on crane strength only. The total rated loads based on stability may lower than those in the above table depending on the loading conditions and the types of the chassis.

Empty Chassis Rated Capacities

Table A

Load Radius	3.77 m / 6.21 m Boom		Load Radius	8.59 m Boom		Load Radius	10.97 m Boom	Load Radius	13.34 m Boom
	Extension width of outriggers			Extension width of outriggers			Extension width of outriggers		Extension width of outriggers
	Full	Minimum		Full	Minimum		Full		Full
2.6 m and below	4,040	2,430	2.6 m and below	3,130	2,430	4.0 m and below	2,230	5.0 m and below	1,430
2.8 m	4,040	2,130	3.4 m	3,130	1,530	4.5 m	1,930	6.0 m	1,130
3.6 m	2,930	1,380	3.6 m	2,930	1,380	5.0 m	1,580	7.0 m	900
3.9 m	2,530	1,180	3.9 m	2,530	1,180	6.0 m	1,130	8.0 m	700
4.5 m	1,930	930	4.5 m	1,930	930	7.0 m	900	9.0 m	550
5.0 m	1,630	730	5.0 m	1,630	730	8.0 m	700	10.0 m	500
5.5 m	1,380	630	5.5 m	1,380	630	9.0 m	550	11.0 m	430
5.99 m	1,130	500	6.0 m	1,130	500	10.0 m	500	12.0 m	400
			6.5 m	1,050	480	10.75 m	450	13.12 m	350
			7.0 m	930	400				
			7.5 m	830	350				
			8.37 m	650	250				

Table B

Load Radius	3.77 m / 6.21 m Boom		Load Radius	8.59 m Boom		Load Radius	10.97 m Boom	Load Radius	13.34 m Boom
	Extension width of outriggers			Extension width of outriggers			Extension width of outriggers		Extension width of outriggers
	Full	Minimum		Full	Minimum		Full		Full
2.5 m and below	4,040	2,930	2.5 m and below	3,130	3,130	4.0 m and below	2,230	5.0 m and below	1,430
2.8 m	4,040	2,430	3.0 m	3,130	2,280	4.5 m	2,180	6.0 m	1,330
3.6 m	3,130	1,680	3.6 m	3,130	1,680	5.0 m	1,930	7.0 m	1,130
3.9 m	2,930	1,430	3.9 m	2,930	1,430	6.0 m	1,430	8.0 m	880
4.5 m	2,430	1,130	4.5 m	2,430	1,130	7.0 m	1,130	9.0 m	730
5.0 m	1,980	930	5.0 m	1,980	930	8.0 m	880	10.0 m	650
5.5 m	1,680	780	5.5 m	1,680	780	9.0 m	730	11.0 m	550
5.99 m	1,430	650	6.0 m	1,430	650	10.0 m	650	12.0 m	500
			6.5 m	1,280	630	10.75 m	580	13.12 m	430
			7.0 m	1,130	530				
			7.5 m	1,030	480				
			8.37 m	830	350				

Table C

Load Radius	3.77 m / 6.21 m Boom		Load Radius	8.59 m Boom		Load Radius	10.97 m Boom	Load Radius	13.34 m Boom
	Extension width of outriggers			Extension width of outriggers			Extension width of outriggers		Extension width of outriggers
	Full	Minimum		Full	Minimum		Full		Full
2.5 m and below	4,040	3,130	2.5 m and below	3,130	3,130	4.0 m and below	2,230	5.0 m and below	1,430
2.8 m	4,040	2,580	3.0 m	3,130	2,580	4.5 m	2,180	6.0 m	1,330
3.6 m	3,130	1,880	3.6 m	3,130	1,880	5.0 m	2,030	7.0 m	1,230
3.9 m	2,930	1,630	3.9 m	2,930	1,630	6.0 m	1,730	8.0 m	1,080
4.5 m	2,530	1,330	4.5 m	2,530	1,330	7.0 m	1,400	9.0 m	950
5.0 m	2,230	1,080	5.0 m	2,230	1,080	8.0 m	1,100	10.0 m	800
5.5 m	1,980	930	5.5 m	1,980	930	9.0 m	950	11.0 m	700
5.99 m	1,730	780	6.0 m	1,730	780	10.0 m	800	12.0 m	630
			6.5 m	1,580	700	10.75 m	730	13.12 m	530
			7.0 m	1,430	630				
			7.5 m	1,250	550				
			8.37 m	1,050	430				

Table D

Load Radius	3.77 m / 6.21 m Boom		Load Radius	8.59 m Boom		Load Radius	10.97 m Boom	Load Radius	13.34 m Boom
	Extension width of outriggers			Extension width of outriggers			Extension width of outriggers		Extension width of outriggers
	Full	Minimum		Full	Minimum		Full		Full
2.5 m and below	4,040	3,380	2.5 m and below	3,130	3,130	4.0 m and below	2,230	5.0 m and below	1,430
2.8 m	4,040	2,580	3.0 m	3,130	2,580	4.5 m	2,180	6.0 m	1,330
3.6 m	3,130	1,880	3.6 m	3,130	1,880	5.0 m	2,030	7.0 m	1,230
3.9 m	2,930	1,630	3.9 m	2,930	1,630	6.0 m	1,730	8.0 m	1,080
4.5 m	2,530	1,330	4.5 m	2,530	1,330	7.0 m	1,430	9.0 m	980
5.0 m	2,230	1,080	5.0 m	2,230	1,080	8.0 m	1,230	10.0 m	880
5.5 m	1,980	930	5.5 m	1,980	930	9.0 m	1,080	11.0 m	800
5.99 m	1,780	780	6.0 m	1,780	780	10.0 m	980	12.0 m	730
			6.5 m	1,630	700	10.75 m	900	13.12 m	650
			7.0 m	1,480	630				
			7.5 m	1,380	550				
			8.37 m	1,180	430				

- NOTES :
1. Empty Chassis Rated Capacities in these tables depend on condition that crane is set level on firm level ground.
 2. The mass of the hook (45 kg), slings and all similarly used load handling devices must be added to the mass of the load.
 3. For boom lengths not shown, use the rated lifting capacity of next longer boom.
 4. When outriggers are extended to middle extension width, use the rated lifting capacities for outriggers are extended to minimum extension width.
 5. For boom lengths longer than 8.59m, extend outriggers to maximum.
 6. 10.97m boom means \sphericalangle mark on 4th boom section side plate is half seen.
 7. Empty Chassis Rated Capacities table A, B, C and D depend on the types of chassis.
 8. Empty Chassis Rated Capacities are shown for over - side areas and over-rear area. These capacities for over - front area may lowered depending on the types of chassis.

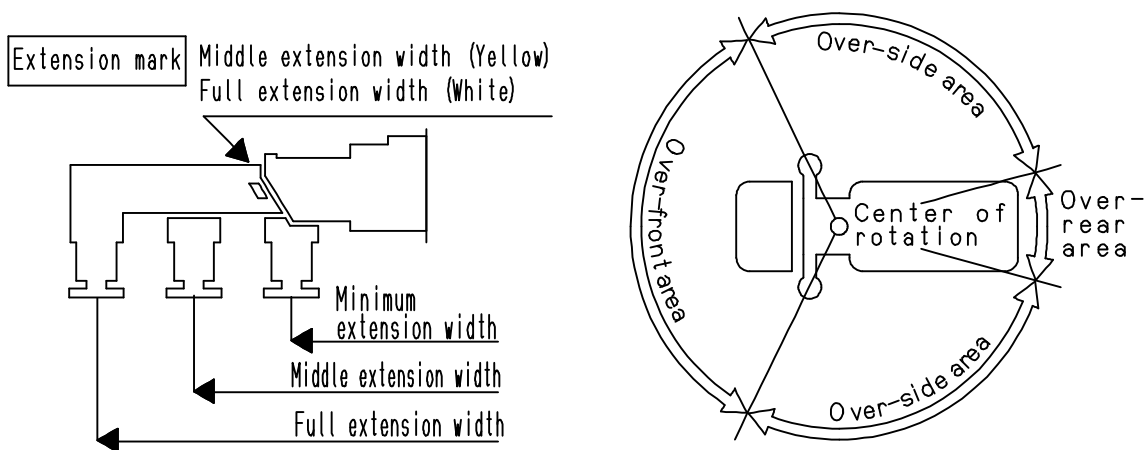

WORKING RANGE

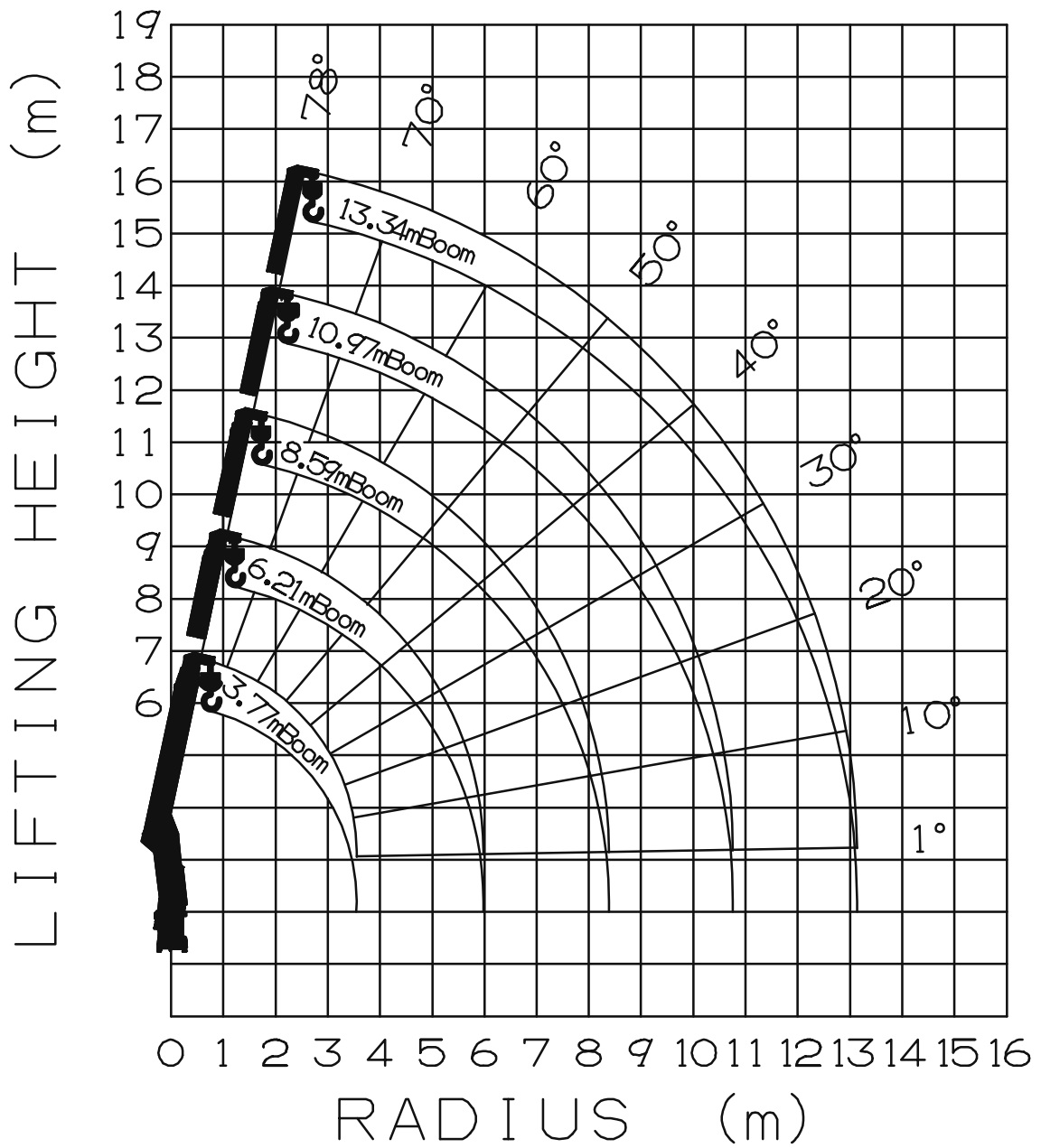

NOTE: The above lifting heights and boom angles are based on a straight (unladen) boom, and allowance should be made for boom deflection obtained under laden conditions.

DIMENSIONS
[TM-ZE505GMH]

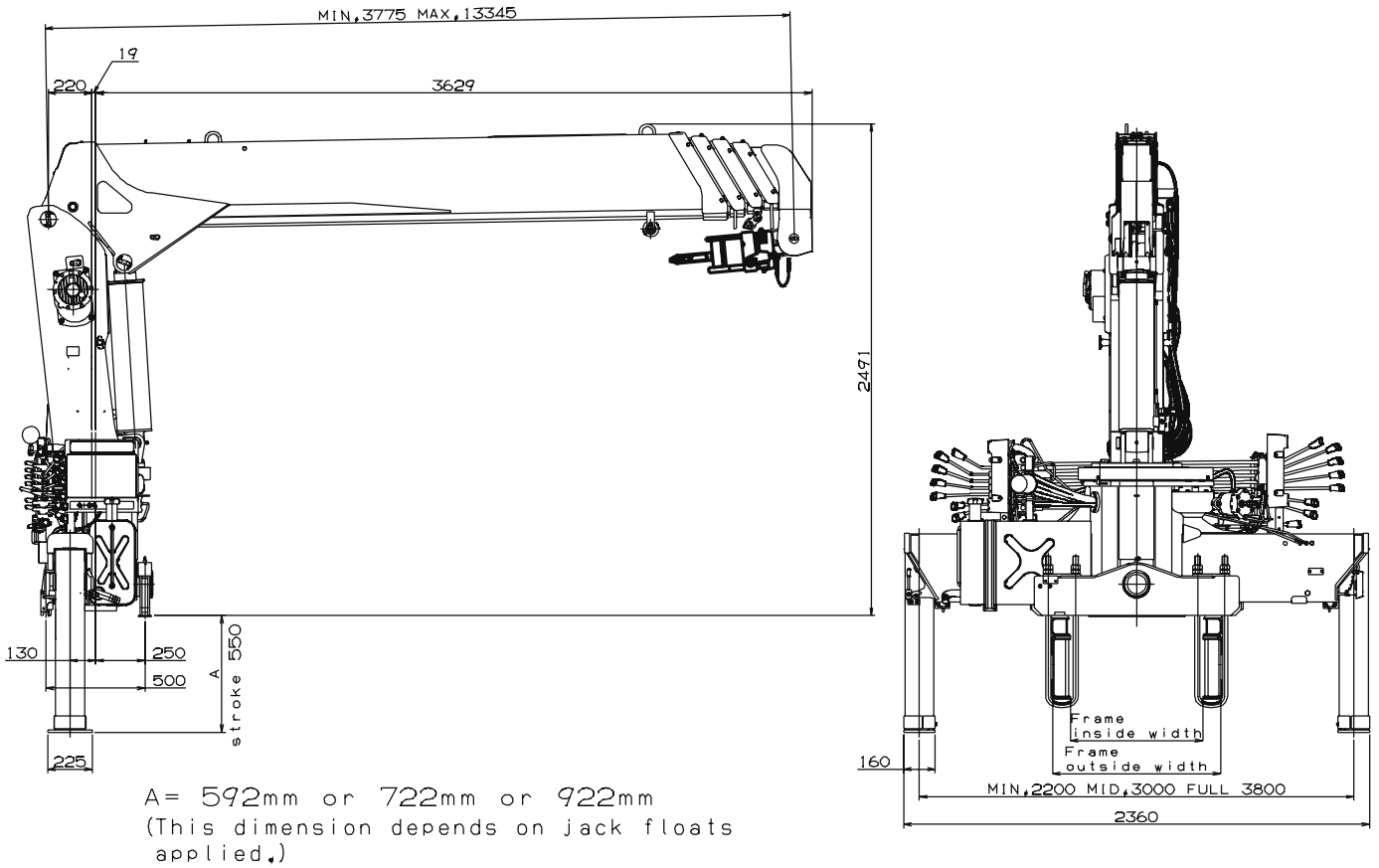

GENERAL DATA FOR SUITABLE TRUCKS

- Gross vehicle mass (including crane mass) ----- 12,000 to 25,000 kg
 - P.T.O. torque ----- 157 N-m{16 kgf-m} min.
 - P.T.O. revolution ----- Approx. 270 to 2,800 min⁻¹{rpm}
 - Width for crane mounting ----- Approx. 750 mm min.
 - Frame ----- Weight distribution and frame strength
should be calculated for each truck
 - Frame width range (inside to outside) ----- Approx. 610 to 960 mm
 - Frame height (ground to frame top) ----- Approx. 1,235 mm max.
- (Height of crane mounting base can be changed
by combination of jack floats and crane bases)